



B.LV5



Biosensor array



Flow-through sensor for bioanalytical applications



Benefits and characteristics



- Enzyme-based amperometric measurement
- Excellent long-term stability
- Stable in continuous monitoring and analyzer mode
- Reference, counter, and blank electrodes on-chip
- Integrated flow cell (small inner volume)
- Suitable for multiparametric measurements
- Outstanding reliability
- Fast response time
- Gamma and beta sterilization compatible
- Suitable for flow-through applications
- For industrial and research applications

Illustration

B.LV5 internal construction

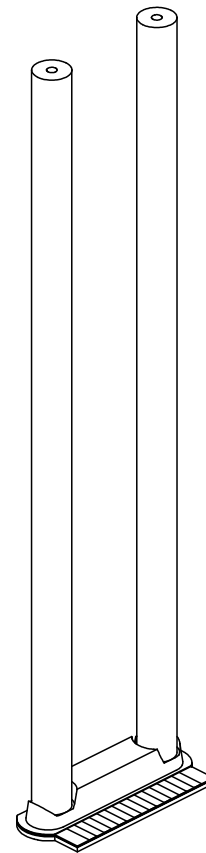
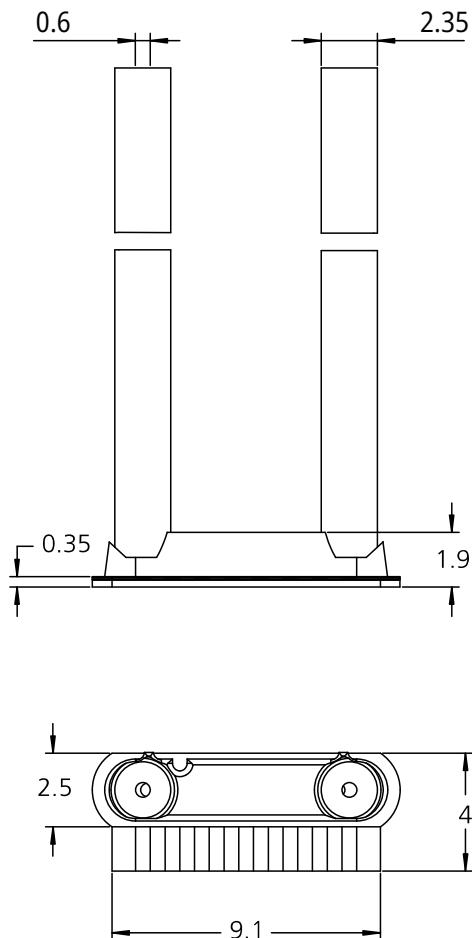

B.LV5 sensor chip with tubes. All dimensions in mm



B.LV5 ruggedized (Luer)

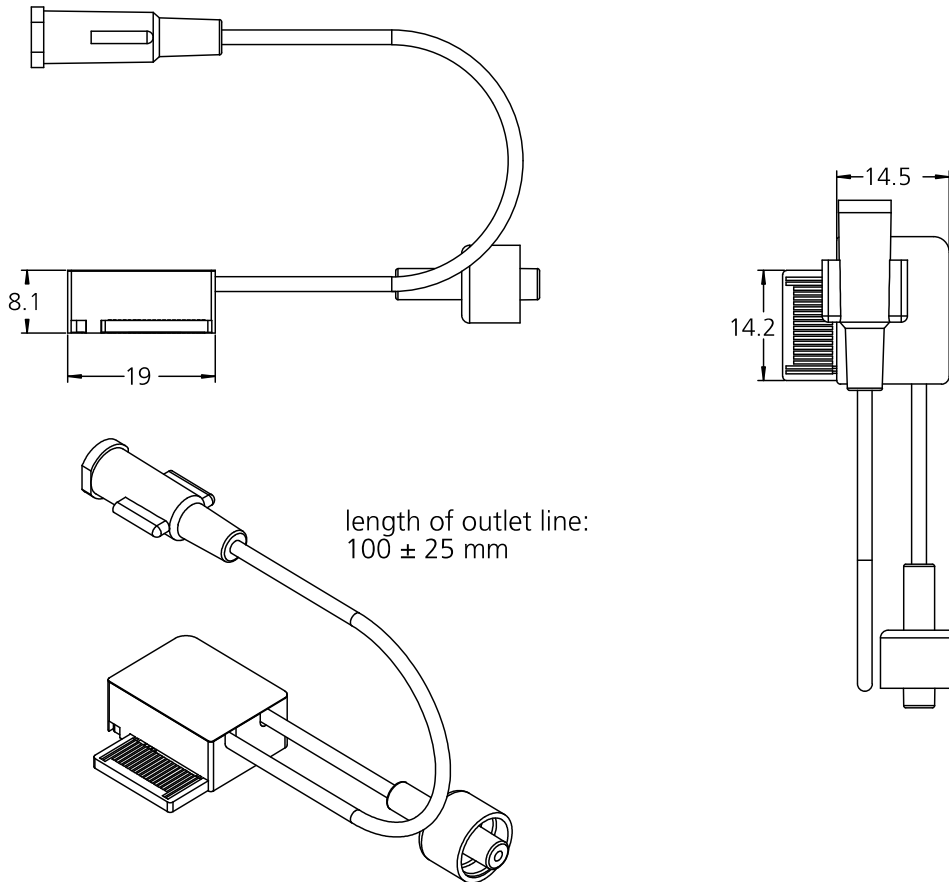

B.LV5 sensor in ruggedized housing and edge card connector compatible to SIX transmitter. All dimensions in mm.

Technical data

Dimensions:	See illustration above. Dimensions in mm	
Measurement principle:	Enzymatic amperometric (oxidase enzymes and H ₂ O ₂ oxidation)	
Working electrode:	Platinum covered with enzyme membrane	
Blank electrode:	For background compensation	
Reference electrode:	Silver/silver chloride	
Counter electrode:	Platinum	
Analytes and measurement range:	Glucose	0.05 mM to 25 mM
	Lactate	0.02 mM to 15 mM
	Glutamine	Contact iST Jobst
	Glutamate	Contact iST Jobst
	Pyruvate	Contact iST Jobst
Notes:	<ul style="list-style-type: none"> - measured in acetate buffer at 37 °C - contact IST AG for buffer composition - other measurement ranges and analytes on request 	
Sensitivity (typical):	Glucose	0.8 nA/mM
	Lactate	2 nA/mM



Sterilization



Irradiation (beta, gamma)

- recommended dose: < 25 kGy

- sensitivity increases according to applied dose

- lifetime decreases according to applied dose



Initial bioburden < 1 CFU per sensor

Do not use organic solvents, for more information, contact iST Jobst



Time ($t_{90\%}$) to first measurement:

~ 15 min at 37 °C in acetate buffer after storage

Response time ($t_{90\%}$):

< 25 s at 37 °C in acetate buffer



Temperature influence:

Glucose: ~3.8 %/K

Lactate: ~3.2 %/K



Storage conditions:

+4 °C to +35 °C, desiccated

Shelf life at recommended storage conditions:

> 6 months (from delivery)

> 2 years from fabrication



Operational lifetime (typical):

Glucose: > 60 days at 20 mM

Lactate: > 7 days at 8 mM

Notes: - measured in acetate buffer at 37 °C

- lifetime may vary in other buffer systems

Operating temperature:

15-42 °C

pH range:

6-8

Drift at 37 °C:

< 5 %/day

Suitable pH buffer systems:

Bicarbonate, acetate, imidazole, for more information, contact iST Jobst

- to be used in buffered media only; not suitable for use with tap- or DI-water

- buffer must contain chloride, $[Cl^-]$ ca. 110 mM

- not suitable for direct use in tap water or DI-water

Flow cell internal volume:

approx. 1.7 μ l (other volumes available on request)

Tubing inner diameter:

0.6 mm

0.3 mm

0.15 mm available on request

Fluidic connection:

Inlet: male Luer lock (only with 0.6-mm tubing)

Outlet: female Luer lock (only with 0.6-mm tubing)

Fluidic operation:

Minimal: 0.3 μ l/min

Maximal: 10 ml/min

Recommended: > 30 μ l/min

Pressure drop: ~ 22 mbar/(ml/min)

Note: measured with a 1,7 μ l flow cell and 10 cm + 10 cm long 0.6 mm iD tubing with Luer locks

Electrical connection:

B.LV5 Sensor bare chip (FPC)

flex-print circuit, 8 pins, 1 mm pitch, 0.35 mm thickness, compatible with FFC/FPC ZIF connectors

B.LV5 Sensor ruggedized (EC)

edge-card, 40 pins in two rows (only 8 are used), 0.635 mm pitch, 1.6 mm thickness, compatible with MEC6-RA socket

General note: Performance data in this document was determined in acetate buffer at 37 °C, pH 7 and normal atmospheric conditions. All parameters may vary in other media.



Product photos

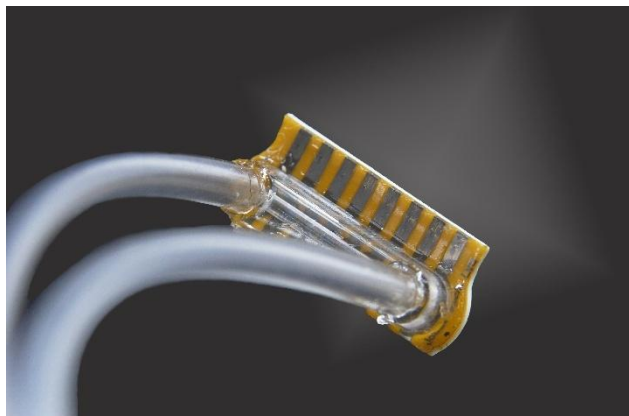

B.LV5 sensor chip with tubes



B.LV5 sensor ruggedized (Luer)

Pin assignment

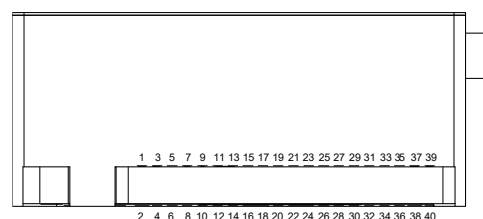
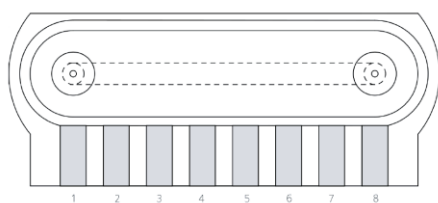

Electrode	B.LV5 Sensor chip	B.LV5 Sensor ruggedized (Luer)
Blank 1	8	26
Glucose1	7	22
Lactate 1	6	28
Blank 2	5	20
Glucose 2	4	16
Lactate 2	3	14
Reference	2	11
Counter	1	7



Order information



Product description	Measured analytes, membrane technology	Product name	Product number	Order code iST
B.LV5 sensor ruggedized (0.6 mm luer)	Glucose, Lactate, standard range	B.LV5.GL.C017.ST.L060.EC.R	1.00101.003	105128
B.LV5 sensor ruggedized (0.6 mm luer)	Glucose, Lactate, xx-range	B.LV5.GL.C017.2X.L060.EC.R	1.00101.010	151522
B.LV5 sensor ruggedized (0.6 mm luer)	Glucose, Lactate, Glutamine, Glutamate standard-range	B.LV5.GLNT.C017.ST.L060.EC.R	1.00101.006	105146
Other constructions	Other analytes Other membranes	On request	On request	On request

Disclaimer

Evaluation product for professionals to be used solely for research and development purposes! Not for medical and diagnostic use. Not to be used on humans. For more information, contact iST Jobst.



Jobst Technologies GmbH • Georges-Köhler-Allee 302 • 79110 Freiburg • Germany
+49 761 55 77 520 • info.jobst@ist-ag.com • www.ist-jobst.com

ALL MECHANICAL DIMENSIONS ARE VALID AT 25 °C AMBIENT TEMPERATURE, IF NOT DIFFERENTLY INDICATED • ALL DATA EXCEPT THE MECHANICAL DIMENSIONS ONLY HAVE INFORMATION PURPOSES AND ARE NOT TO BE UNDERSTOOD AS ASSURED CHARACTERISTICS • TECHNICAL CHANGES OR PRODUCT SPECIFICATIONS WITHOUT PREVIOUS ANNOUNCEMENT RESERVED • THE INFORMATION ON THIS DATA SHEET WAS EXAMINED CAREFULLY AND WILL BE ACCEPTED AS CORRECT; NO LIABILITY IN CASE OF MISTAKES • LOAD WITH EXTREME VALUES DURING A LONGER PERIOD CAN AFFECT THE RELIABILITY • THE MATERIAL CONTAINED HEREIN MAY NOT BE REPRODUCED, ADAPTED, MERGED, TRANSLATED, STORED, OR USED WITHOUT THE PRIOR WRITTEN CONSENT OF THE COPYRIGHT OWNER • ALL RIGHTS RESERVED.